

THE HAWKE EMC TRANSIT SYSTEM

Stainless Steel Stayplates

Installed to anchor insert and filler blocks into the frame and ease assembly. They also increase the conductance throughout the frame.

Tolerant insert and filler blocks.

Made from an intumescent flame retardant elastomer coated on all surfaces with a silver loaded spray which is highly conductive and provides the excellent shielding ability. In addition, a layer of adhesive copper strip is applied around the block to aid conductivity. Hawke blocks can accommodate cables ranging from 3mm to 100mm diameter, and include tolerant blocks which allow for variations in cable diameters by using five individual sealing faces which take up the cable variations within their own individual areas.

Note:

Block module size should be suffixed E (e.g. 3012/E). The adhesive EMI Shielding Tape is available in the following lengths:
Size 18 = 16.5m
Size 36 = 32.9m

The Compression System

Seals the penetration when all the services have been installed. The 3 part endpacker transmits an evenly distributed pressure onto the compression plate and ensures an effective seal around the cables.

The materials:

Packing blocks - intumescent flame retardant elastomer coated with a silver loaded spray and wrapped with copper strip for effective shielding. End packer plates - Electro zinc plated steel or stainless steel. Compression plates - Electro zinc plated cast steel.

Adhesive Copper Strip

Provided to build up to the insert blocks and the stripped cable. The cable outer sheath should be stripped to a maximum width of 2cm to expose the cable screen. All the cables require the removal of the outer sheath to achieve contact between the cable screen and the blocks. The copper EMI shielding tape with conductive adhesive is wrapped around the cable screen until the nominal outside diameter of the cable is achieved. This is important to ensure complete conductance of the electromagnetic pulses/fields in the inner walls of the steel frame against earth.

The Frame

The electro zinc plated steel or stainless steel frame is attached to the structure and forms the surround for the penetration.

PERFECTION INVITES CLOSER INSPECTION

EMC TRANSIT SYSTEM INSTALLATION GUIDE

EMC Transit System

The following diagrams explain step by step how easy it is to install EMC Hawke cable/pipe tolerant blocks into EMC Transit frames.



1 Draw up a Hawke Design Template to determine your cable/pipe layout.

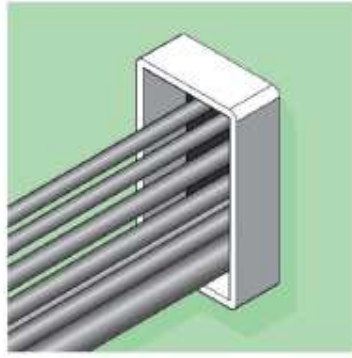

2 Make sure the frame is clean, then pull cables or pipes through, placing the largest at the bottom. (Note: Use open ended frame to fit around existing cables/pipes).

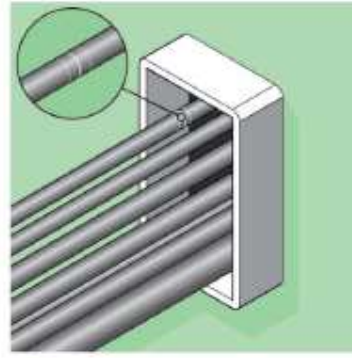

3 Mark each cable in the centre of the frame and 7-8mm either side of this point.

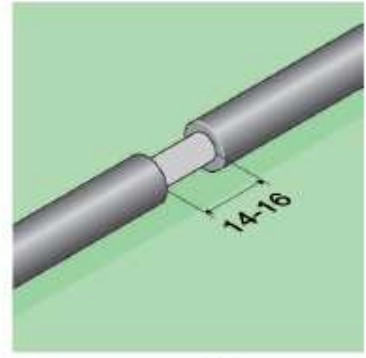

4 Cut and remove cable sheath between two outside marks, to expose the cables conductive screen.

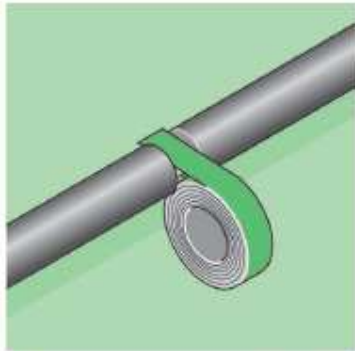

5 Using copper tape provided tightly wrap around the exposed screen until the cable outer diameter is regained. Repeat steps 3, 4 & 5 for all cables.

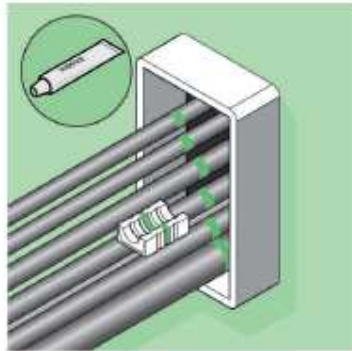

6 Very slightly lubricate the insert blocks taking care not to contaminate the copper tape on block or cable.

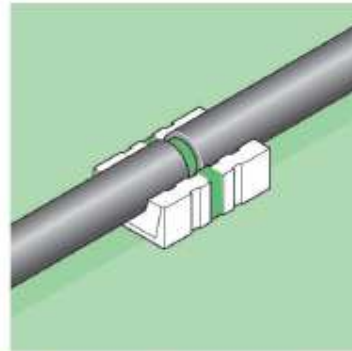

7 Ensure when fitting cables into blocks that the copper tapes on block and cable align.

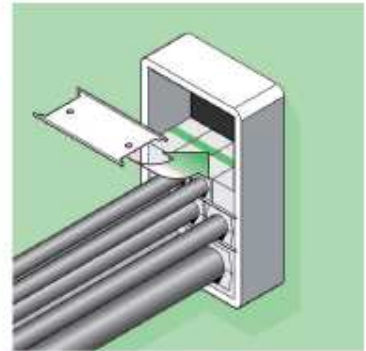

8 Begin packing the frame. A stayplate is inserted between each layer of insert blocks.

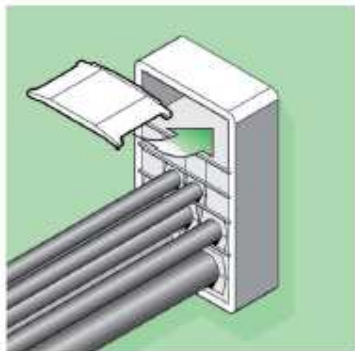

9 Insert the compression plate before the last row of blocks or earlier if required with additional stayplates.

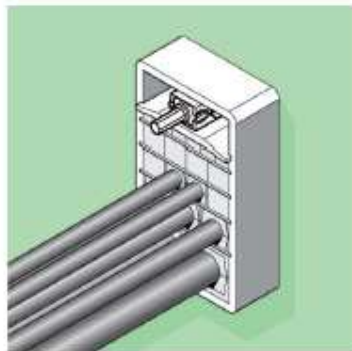

10 Pack the last row, insert the compression tool and tighten until there is sufficient room to fit the tapered end packers.

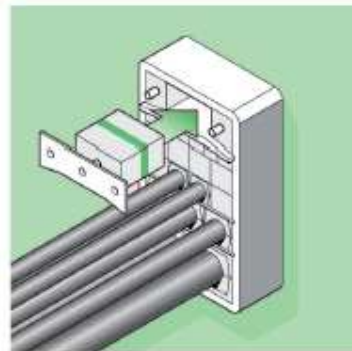

11 Insert two outside packing pieces then remove tool before fitting centre block.

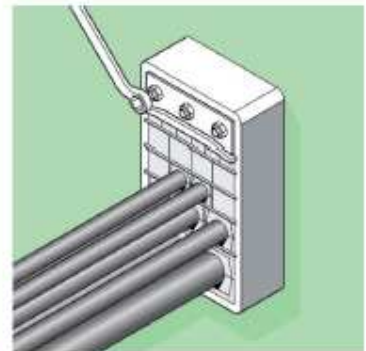

12 Tighten the nuts on the endpacking to compress and complete the seal. Approximately 10mm of thread should protrude on each bolt.

If possible after completion the assembly should be tested for conductivity

FOR CABLES AND PIPES

Testing Procedures

Hunting Communication Technology Limited, Electromagnetic Assessment Group, were referred to as specialists with extensive testing facilities. A series of three specified tests were recommended to assess the transit performance and provide design data.

Fig 1.- Test for Shielding Effectiveness (No. U2501/TR/6660)

The aim of the test was to measure the shielding effectiveness of the Transit by a method generally in accordance with MIL STD 285. The testing was actually performed using a swept measurement technique employing a spectrum analyser with tracking generator to 1GHz and a Scalar network analyser from 1GHz to 10GHz.

Conclusion:

The Transit showed good shielding results being in excess of 70dB over much of the tested frequency range.



Fig 1.- Test for Shielding Effectiveness (No. U2501/TR/6660)

Fig 2.- Test for Current Leakage (No. U2501/TR/6661)

The test was designed to assess the conductivity of the Transit when used with a variety of cables. As there is not a standard specification for this assessment, a test method was formulated which measured the conductivity in terms of current leakage from the cable shield to earth within a frequency range of 100KHz to 500MHz.

Conclusion:

Based upon the worst case data obtained, it was observed that the current leakage was better than 35dB over the frequency range 100KHz to 500MHz. In fact, for most of the frequency range the current leakage was at least 50db.

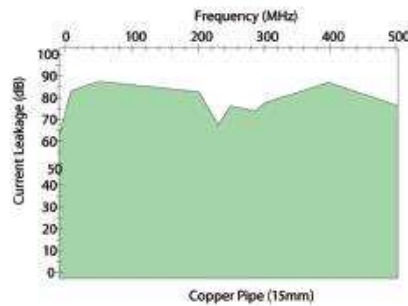

Fig 2.- Test for Current Leakage (No. U2501/TR/6661)

Fig 3.- Test for transient (pulse) conductivity (No. 2501/TR/6662)

The tests involved assessing the transient conductivity of the Transit when used with a variety of cables. The method used measured the conductivity in terms of current leakage from the cable shield to earth under the transient conditions. The test was based upon DEF STAN 59-41 using transients consisting of a 100KHz damped sinusoid applied by a current transformer.

Conclusion:

The current leakage under transient conditions for the cable set ups tested show a minimum insertion loss of 30dB.

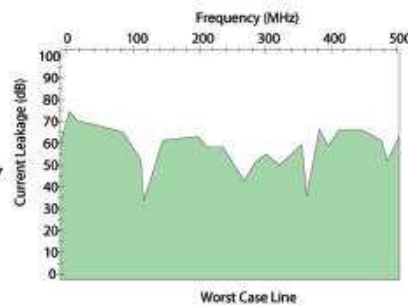

Fig 3.- Test for transient (pulse) conductivity (No. 2501/TR/6662)

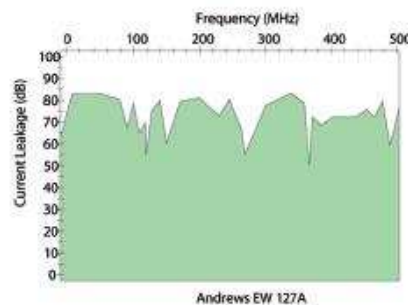

Fig 3.- Test for transient (pulse) conductivity (No. 2501/TR/6662)

Hawke

EMC Transit System for Cables and Pipes



The Hazards of RFI/EMP

The need to protect sensitive electronic equipment against extraneous electromagnetic and radio frequency radiation is an increasing and critical factor in the design of equipment and installations.

A major concern is to ensure the integrity of operation of the equipment such as computers, signalling control and communication systems by effective sealing and low resistance earth continuity bonding at cable and pipe entry points of a low 'noise' environment.

Electromagnetic Compatibility (EMC). This is the term used to express the ability of electronic equipment or systems to operate satisfactorily in a given environment without responding to electrical noise or emitting unwanted noise.

The Hawke EMC Cable Transit System. Hawke's system has been further developed from the highly successful Civil and Marine Transits which are equally suitable for cables or pipes.

Electromagnetic compatibility is achieved by reducing the Electromagnetic interference (EMI) to a level which in most applications will not disrupt the proper operation of the electronics.